

GRINDMIX 'V' Series

our engineering your satisfaction...

Features :

- V-Series is a batch type machine in which grinding & mixing is performed simultaneously.
- V-Series is used to manufacture poultry feed, cattle feed, goat feed, shrimps feed & fertilizers. (For dry materials & mash type only)
- Strong & rigid steel construction.
- Minimum floor area required (as mentioned in the table below)
- High gain in minimum H.P. consumption.
- Requires minimum labour.
- Foundation is not must.
- Minimum noise.
- Materials like dry whole fish can be ground with other raw materials.
- Machine can be comfortably transferred from one place to another.

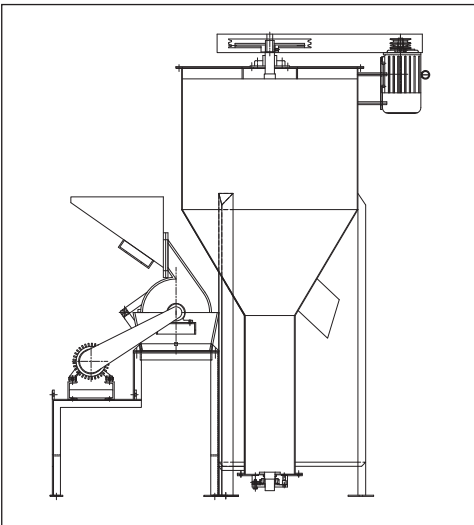

| MODEL | GRINDMIX HSSB | | | | | |
|--------------------|---------------|-------|--------------------------|----------------------------|-----|------|
| | HORSE POWER | | CAPACITY PER 8 hr. SHFIT | FLOOR AREA(APP.) (In Mts.) | | |
| | GRINDER | MIXER | | L | W | H |
| GRINDMIX V-150 kg. | 2 or 3 | 1 | 3 to 4 Tons | 1 | 1.7 | 2 |
| GRINDMIX V-300 kg. | 5 | 2 | 6 to 7 Tons | 1.25 | 1.9 | 2.15 |
| GRINDMIX V-500 kg. | 7.5 | 3 | 9 to 10 Tons | 1.5 | 2.1 | 2.5 |

OUR PRODUCTS

- Hammer Mills.
- Mixers and Blenders.
- Hoppers.
- Pellet Mills.
- Total Mash & Pellet Plants
- Counterflow Coolers / Rotary Coolers.
- Crumblers.
- Gyroscreens / Vibrosieves.
- Material handling systems and conveyors

OUR PRODUCTS APPLICATIONS

- Poultry feed plants.
- Animal feed plants.
- Organic fertilizer plants.
- Biomass pellet plants.
- Shell grit plants.
- Fish meal plants.
- Pharmaceuticals.
- Paint Industries.
- Food Industries.
- Grain Handling.